

MARATHON 55 & 90

For sliding doors. Max 55kg or 90kg.

APPLICATION

- Used for heavy-duty domestic and light commercial applications, doors and partitions
- For timber, timber framed or composite doors
- Easily adjusted door height
- Simultaneous action option
- Fire door kit option available for Marathon 90

DOOR SPECIFICATION

Track System	Marathon 55	Marathon 90
For Individual Doors:		
Max Door Weight	55kg	90kg
Max Door Width	1500mm	1500mm
Door Thickness	32-50mm	32-50mm
Max Door Height	3000mm	3000mm

STANDARD SETS AND PACK

Sets comprise of top assembly, nylon top plates, floor guide, nylon, channel, wall mounted stop, all screws and fitting instructions.

Marathon 55 Set No.	Marathon 90 Set No.	Door width	Track length	Hardware for
HJ2	HS2	400-750mm	1219mm	1 door
HJ3	HS3	750-900mm	1473mm	1 door
HJ4	HS4	900-1050mm	1702mm	1 door
HJ5	HS5	1050-1200mm	1981mm	1 door
HJ6	HS6	1200-1500mm	2438mm	1 door

HARDWARE SPECIFICATION

Top plate (2 per door)	H43	Nylon top plate with integral buffer (<i>not supplied with bolt</i>)
Stop	H44	Wall mounted stop
Guides	H101N H102N H102N/93	Nylon saw cut guide Nylon saw cut guide Floor mounted channel guide
Channels	H94X	Aluminium (<i>2000, 3000, 4000 & 6000mm lengths</i>)
Accessories		
Self closing kit	H5CK1	For doors up to 60kg
Pelmet	H40P/1854	Galvanised fascia for face fixed applications (<i>HJ3 and HS3 sets only</i>)
	HEC40P	Galvanised fascia end cap
	H40P/1854	Galvanised fascia for face fixed applications (<i>HJ3 and HS3 sets only</i>)
Bracket	H3/40	Soffit fix brackets (<i>pack of 5</i>)
Fire door kit	HFDK1	Self closing fire door kit. For use in conjunction with Marathon kits S3, S4, S5 & S6 (<i>purchased separately</i>)
	HFDK2	Non-self closing fire door kit. For use in conjunction with Marathon kits S3, S4, S5 & S6 (<i>purchased separately</i>)
Simultaneous Action Kit	H23	For biparting doors up to 60kg

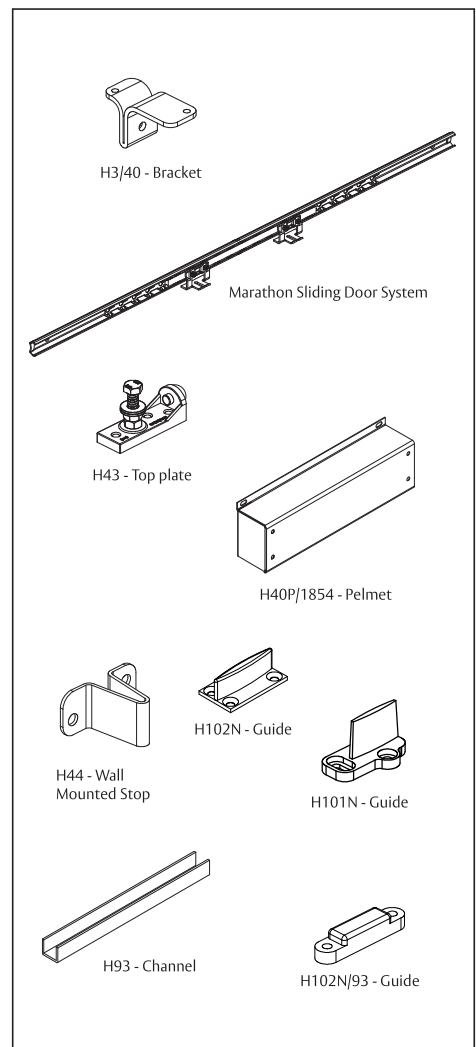

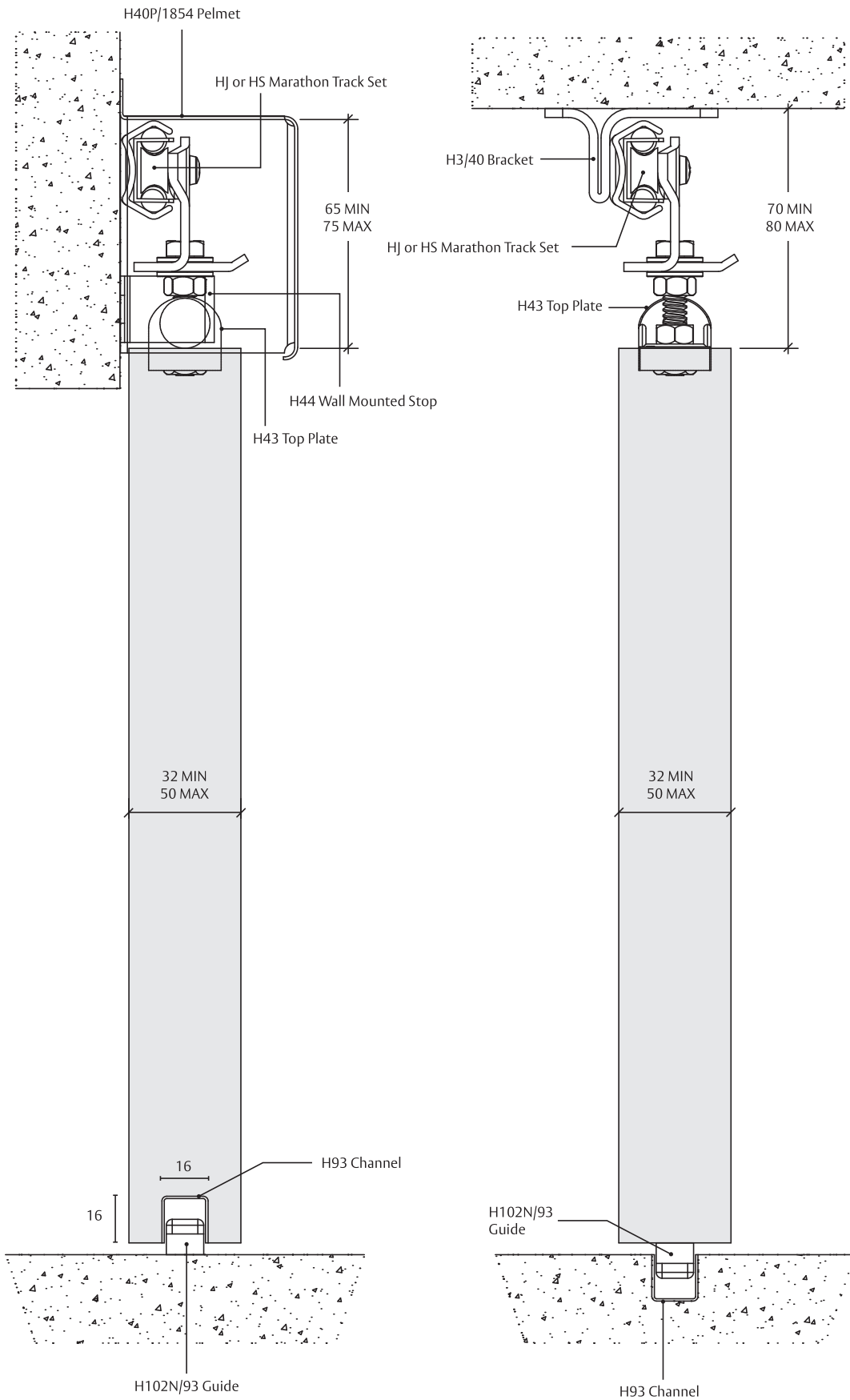

HENDERSON